

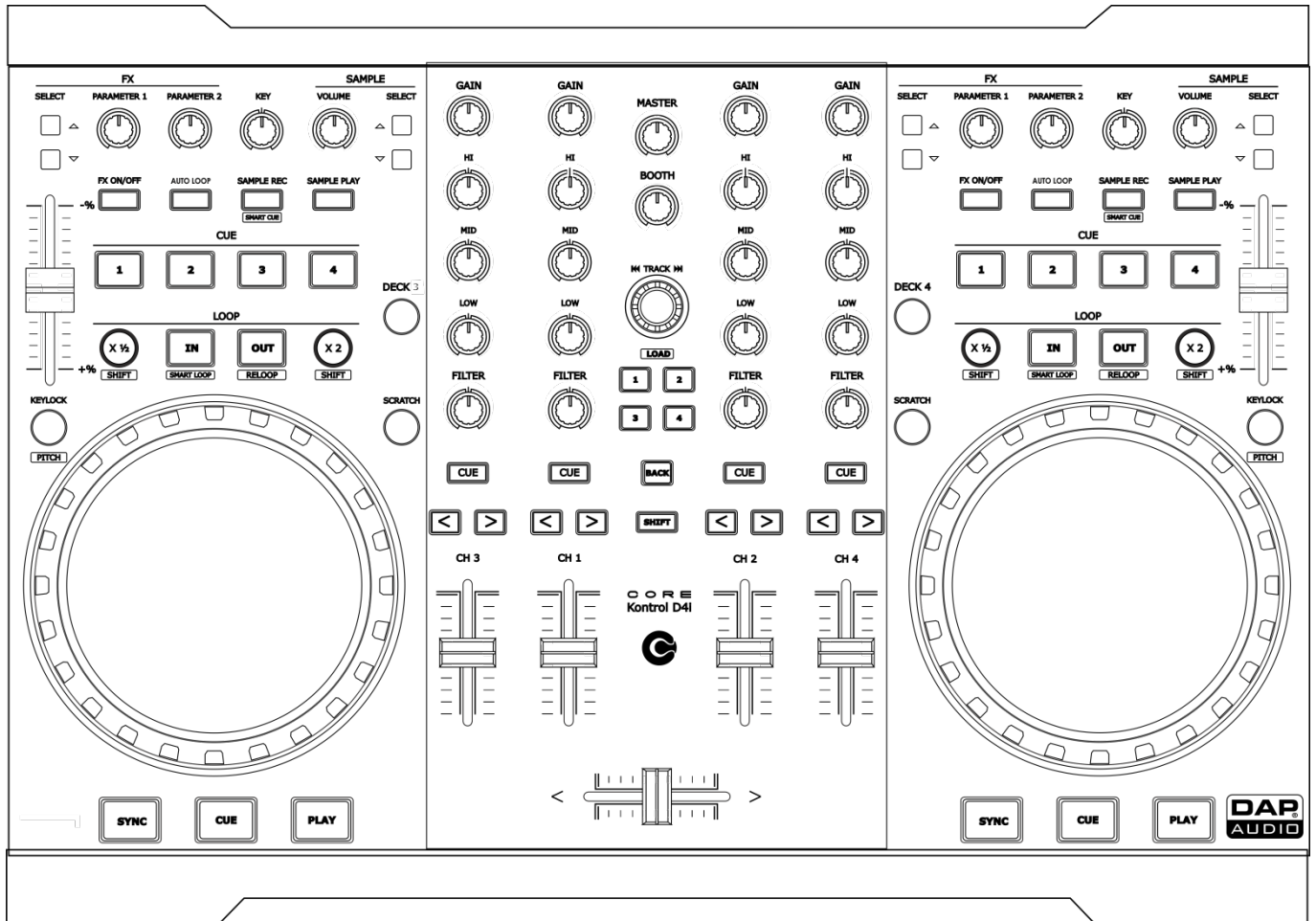

MANUAL



ENGLISH

Core Kontrol D4i

V1

Ordercode: D1260

Table of contents

Warning	2
Safety Instructions.....	2
Operating Determinations.....	3
Return Procedure	4
Claims	4
Description of the device	5
Overview.....	5
Deck 1-3/2-4	6
Mixer.....	7
Frontside.....	8
Backside.....	8
Installation	8
Set Up and Operation	8
Names and Functions	9
Deck Functions	9
Mixer Functions	11
Front Functions.....	12
Back Functions.....	13
Operations	14
Selecting Folders.....	14
Selecting tracks using the track select encoder.....	14
Starting Playback	14
Stop Playback.....	14
Pausing	14
Setting a Cue Point	14
Setting a hot cue point in pause mode.....	14
Setting a hot cue point in play mode	15
Deleting a hot cue point	15
Cueing.....	15
Seek (fast forward/fast backward).....	15
Changing pitch of the song.....	15
Pitch bending.....	15
Loop play	16
Auto loop play	16
Reloop	16
Recording a sample	16
Sample playback.....	16
Software Installation	17
Running the setup program.....	18
Running the Virtual DJ-software for the first time	21
Interface zones	23
Browser panels.....	24
Sampler panels.....	24
Effects panels.....	24
Record panels.....	24
Maintenance	25
Troubleshooting	25
Product Specification	27
Appendix 1: Midi Implementation	28
Notes	34

Warning



**For your own safety, please read this user manual carefully
before your initial start-up!**



Unpacking Instructions

Immediately upon receiving this product, carefully unpack the carton and check the contents to ensure that all parts are present, and have been received in good condition. Notify the dealer immediately and retain packing material for inspection if any parts appear damaged from shipping or the carton itself shows signs of mishandling. Save the carton and all packing materials. In the event that a fixture must be returned to the factory, it is important that the fixture be returned in the original factory box and packing.

Your shipment includes:

- DAP Kontrol D4i
- USB cable 1,5 m
- CD with Virtual DJ LE software
- User manual
- Power adapter



CAUTION!
Keep this device away from rain and moisture!
Unplug mains lead before opening the housing!



Safety Instructions

Every person involved with the installation, operation and maintenance of this system has to:

- be qualified
- follow the instructions of this manual



CAUTION! Be careful with your operations.
**With a dangerous voltage you can suffer
a dangerous electric shock when touching the wires!**



Before you initial start-up, please make sure that there is no damage caused by transportation. Should there be any, consult your dealer and do not use the system.

To maintain perfect condition and to ensure a safe operation, it is absolutely necessary for the user to follow the safety instructions and warning notes written in this manual.

Please consider that damages caused by manual modifications to the system are not subject to warranty.

This system contains no user-serviceable parts. Refer servicing to qualified technicians only.

IMPORTANT:

The manufacturer will not accept liability for any resulting damages caused by the non-observance of this manual or any unauthorized modification to the system.

- Never remove warning or informative labels from the unit.
- Never leave any cables lying around.
- Do not connect this system to a dimmerpack.
- Do not switch the system on and off in short intervals, as this would reduce the system's life.
- Do not open the device and do not modify the device.
- Do not drive the inputs with a signal level bigger, than required to drive the equipment to full output.
- Only use system indoor, avoid contact with water or other liquids.
- Avoid flames and do not put close to flammable liquids or gases.
- Make sure you don't use the wrong kind of cables or defective cables.
- When using a power adaptor, make sure that the available voltage is not higher than stated on the rear panel.
- Please turn off the power switch, when changing the power adaptor or signal cable.
- Extreme frequency boosts in connection with a high input signal level may lead to overdriving your equipment. Should this occur, it is necessary to reduce the input signal level by using the INPUT control.
- To emphasize a frequency range, you don't necessarily have to move its respective control upward; try lowering surrounding frequency ranges instead. This way, you avoid causing the next piece of equipment in your sound path to overdrive. You also preserve valuable dynamic reserve ("headroom").
- Avoid ground loops! Always be sure to connect the power amps and the mixing console to the same electrical circuit to ensure the same phase!
- If system is dropped or struck, disconnect the power supply or USB cable immediately. Have a qualified engineer inspect for safety before operating.
- If the system has been exposed to drastic temperature fluctuation (e.g. after transportation), do not switch it on immediately. The arising condensation water might damage your system. Leave the system switched off until it has reached room temperature.
- If your Dap Audio device fails to work properly, discontinue use immediately. Pack the unit securely (preferably in the original packing material), and return it to your Dap Audio dealer for service.
- Repairs, servicing and electric connection must be carried out by a qualified technician.
- For replacement use fuses of same type and rating only.

Operating Determinations

This system is not designed for permanent operation. Consistent operation breaks will ensure that the system will serve you for a long time without defects.

If this system is operated in any other way, than the one described in this manual, the product may suffer damages and the warranty becomes void.

Any other operation may lead to dangers like short-circuit, burns, electric shock, etc.

You endanger your own safety and the safety of others!

Improper installation can cause serious injuries and damage of property !



Return Procedure



Returned merchandise must be sent prepaid and in the original packing, call tags will not be issued. Package must be clearly labeled with a Return Authorization Number (RMA number). Products returned without an RMA number will be refused. Highlite will not accept the returned goods or any responsibility. Call Highlite 0031-455667723 or mail aftersales@highlite.nl and request an RMA prior to shipping the fixture. Be prepared to provide the model number, serial number and a brief description of the cause for the return. Be sure to properly pack fixture, any shipping damage resulting from inadequate packaging is the customer's responsibility. Highlite reserves the right to use its own discretion to repair or replace product(s). As a suggestion, proper UPS packing or double-boxing is always a safe method to use.

Note: If you are given an RMA number, please include the following information on a piece of paper inside the box:

- 01) Your name
- 02) Your address
- 03) Your phone number
- 04) A brief description of the symptoms

Claims

The client has the obligation to check the delivered goods immediately upon delivery for any shortcomings and/or visible defects, or perform this check after our announcement that the goods are at their disposal. Damage incurred in shipping is the responsibility of the shipper; therefore the damage must be reported to the carrier upon receipt of merchandise.

It is the customer's responsibility to notify and submit claims with the shipper in the event that a device is damaged due to shipping. Transportation damage has to be reported to us within one day after receipt of the delivery.

Any return shipment has to be made post-paid at all times. Return shipments must be accompanied with a letter defining the reason for return shipment. Non-prepaid return shipments will be refused, unless otherwise agreed in writing.

Complaints against us must be made known in writing or by fax within 10 working days after receipt of the invoice. After this period complaints will not be handled anymore.

Complaints will only then be considered if the client has so far complied with all parts of the agreement, regardless of the agreement of which the obligation is resulting.

Description of the device

Features

The Kontrol D4i is a DAP audio Core series is a 4 Channel Midi controller with 2 analog inputs.

Note: The virtual DJ LE software version does not support analog inputs. To take full advantage of all functions of your Kontrol D4i, you need to buy the Virtual DJ Pro Full version.

- Large 134mm jog-wheels with adjustable touch sensitivity
- 4 Deck controller for any kind of DJ software
- Booth monitor & balanced master output
- Microphone input
- 2 analog inputs (not supported by the virtual DJ LE software)
- 4 in, 4 out audio interface
- Including Virtual DJ LE

Overview

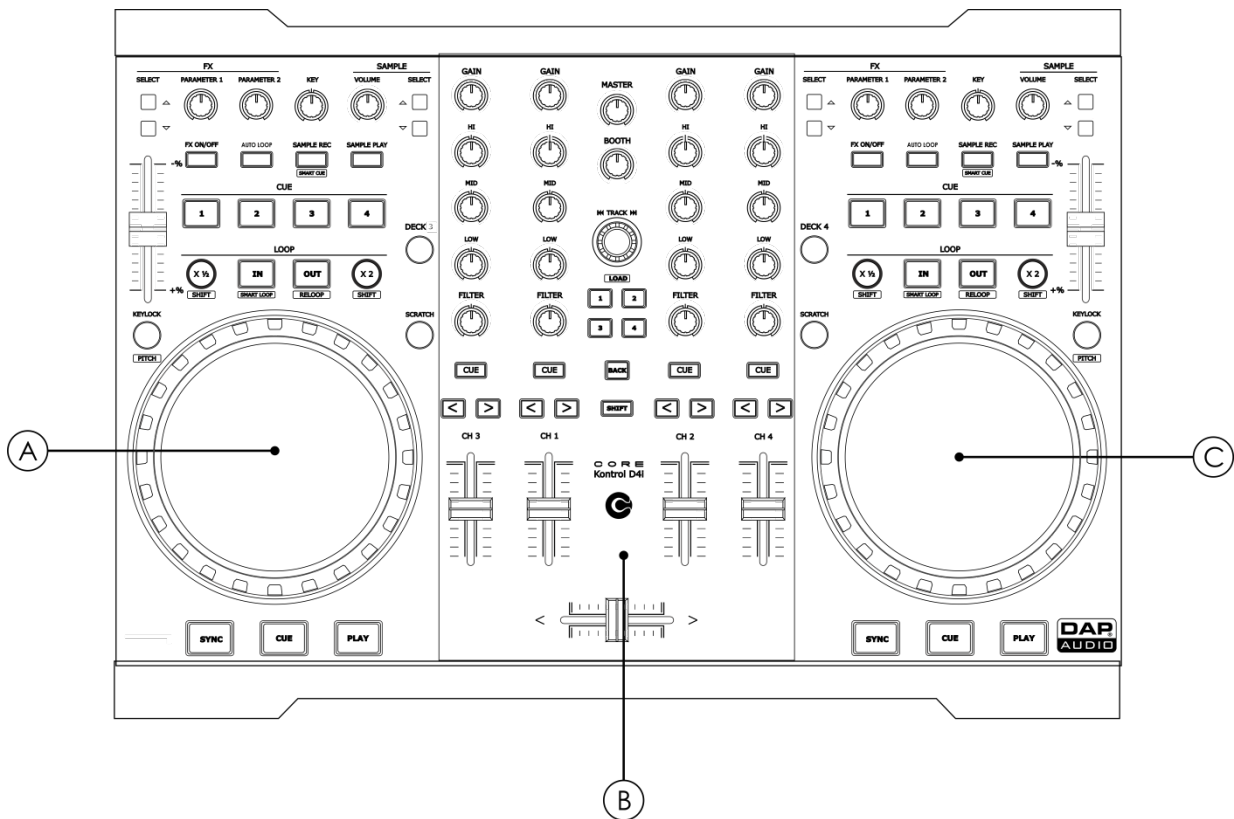

Fig. 01

A Deck A

B Mixer

C Deck B

Deck 1-3/2-4

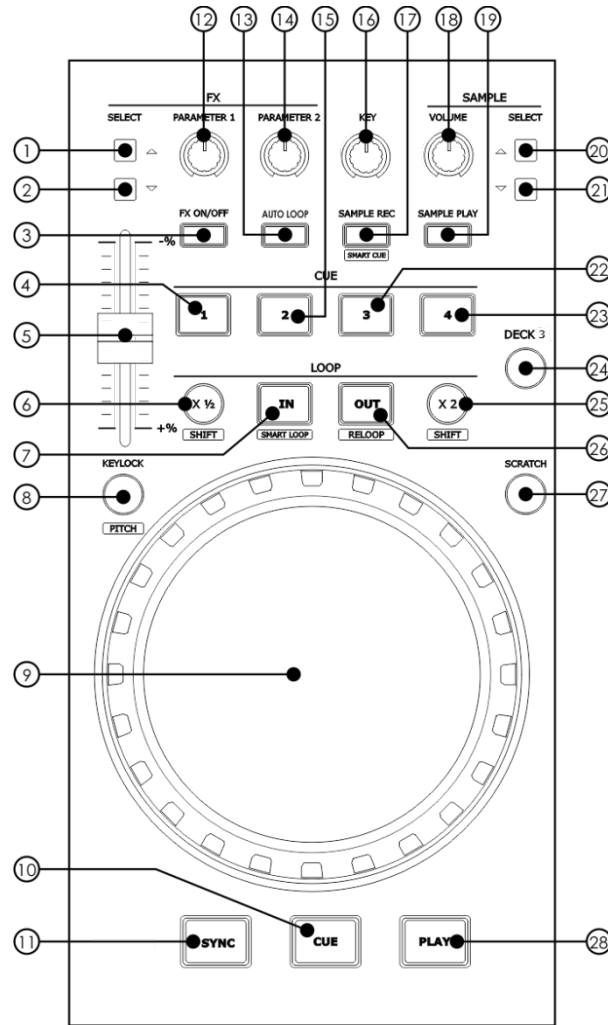

Fig. 02

- | | |
|-----------------------------|-------------------------------|
| ① FX select up button | ⑮ Hotcue 2/4 beats button |
| ② FX select down button | ⑯ Key control |
| ③ FX on/off button | ⑰ Sample rec/smart cue button |
| ④ Hotcue 1/2 beats button | ⑱ Sample volume control |
| ⑤ Pitch control fader | ⑲ Sample play button |
| ⑥ x½/shift button | ⑳ Sample select up button |
| ⑦ Loop in/smart loop button | ㉑ Sample select down button |
| ⑧ Key lock/pitch button | ㉒ Hotcue 3/8 beats button |
| ⑨ Jogwheel | ㉓ Hotcue 4/16 beats button |
| ⑩ Cue button | ㉔ Deck 3 button |
| ⑪ Sync/master button | ㉕ x2/shift button |
| ⑫ Parameter 1 control | ㉖ Loop out/reloop button |
| ⑬ Auto loop button | ㉗ Scratch button |
| ⑭ Parameter 2 control | ㉘ Play button |

Mixer

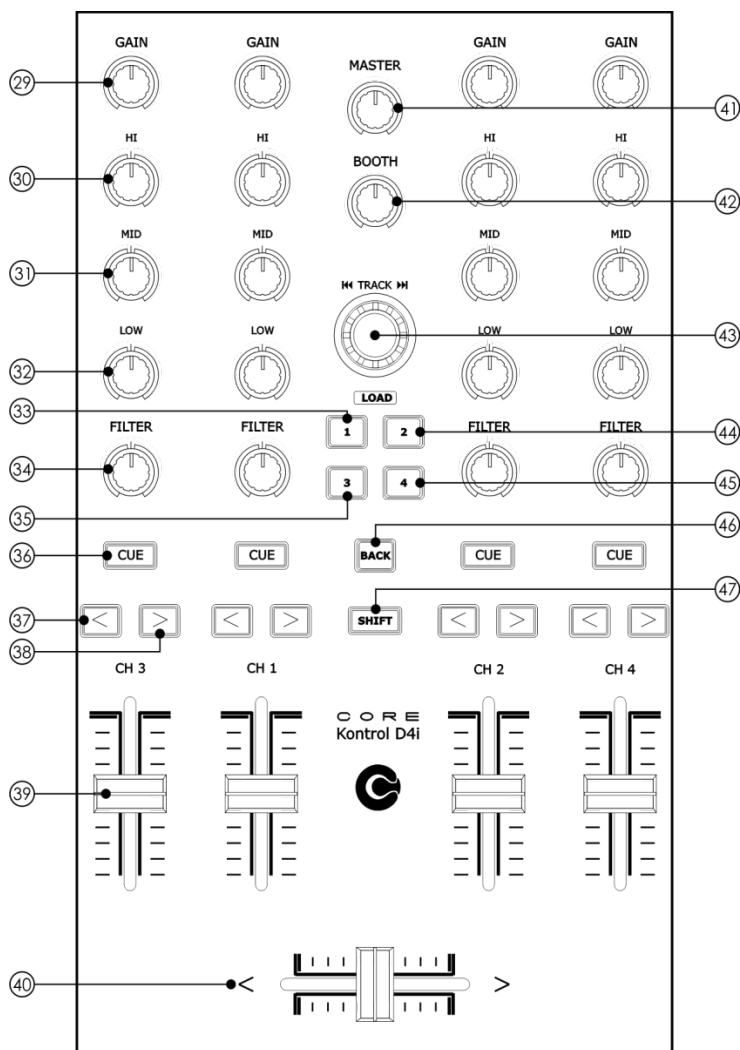

Fig. 03

- | | |
|-------------------------------|-------------------------|
| ②9 Channel gain control | ③9 Channel fader |
| ③0 Channel hi control | ④0 Crossfader |
| ③1 Channel mid control | ④1 Master control |
| ③2 Channel low control | ④2 Booth control |
| ③3 Load/view 1 button | ④3 Track select encoder |
| ③4 Filter control | ④4 Load/view 2 button |
| ③5 Load/view 3 button | ④5 Load/view 4 button |
| ③6 Cue button | ④6 Back button |
| ③7 Crossfader assign L switch | ④7 Shift button |
| ③8 Crossfader assign R switch | |

Frontside

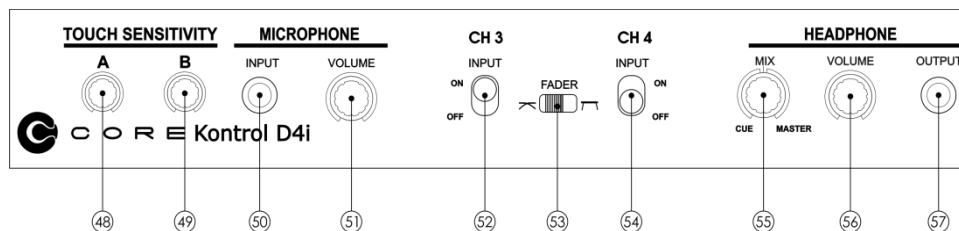

Fig. 04

- ④8 Touch sensitivity control jogwheel A
- ④9 Touch sensitivity control jogwheel B
- ⑤0 Mic input jack (6,3 mm)
- ⑤1 Mic volume control
- ⑤2 Channel 3 input switch
- ⑤3 Crossfader slope switch
- ⑤4 Channel 3 input switch
- ⑤5 Cue mix control
- ⑤6 Headphones volume control
- ⑤7 Headphones output jack (6,3 mm)

Backside

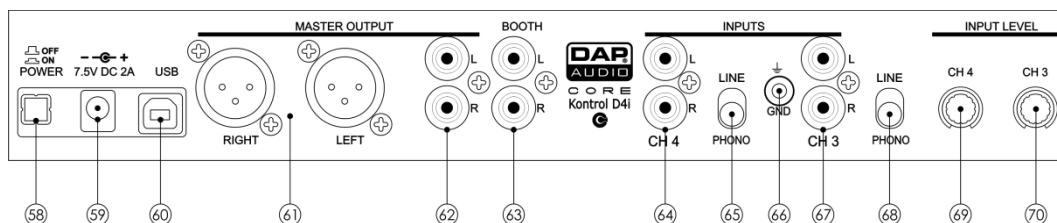

Fig. 05

- ⑤8 Power on/off switch
- ⑤9 DC In 7,5V 2A
- ⑥0 USB connector B
- ⑥1 Master XLR out L/R
- ⑥2 Master RCA out L/R
- ⑥3 Booth RCA out L/R
- ⑥4 Channel 4 RCA input
- ⑥5 Channel 4 line/phono switch
- ⑥6 GND screw
- ⑥7 Channel 3 RCA input
- ⑥8 Channel 3 line/phono switch
- ⑥9 Channel 4 input level control
- ⑦0 Channel 3 input level control

Installation

Remove all packing materials from the Kontrol D4i. Check that all foam and plastic padding is removed. Connect all cables.

Always disconnect from electric mains power supply before cleaning or servicing.
Damages caused by non-observance are not subject to warranty.

Set Up and Operation

Before plugging the unit in, always make sure that the power supply matches the product specification voltage. The power supply demands are printed on the back of the device.

Connection:

- 01) Connect the Kontrol D4i to your mixer/amplifier using the proper cables.
- 02) Connect the supplied power adapter.

CAUTION: Be sure that the mixer/amplifier's power is off, when connecting the cables. Turn on the Kontrol D4i before you turn on your mixer/amplifier.

Names and Functions

Below is a description of the functions of the controls.

Deck Functions

01) Effects select up button

Tapping this button allows you to select one of the available effects in forward direction. The included Virtual DJ LE software gives you access to seven effects as shown below.

02) Effects select down button

Tapping this button allows you to select one of the available effects in backwards direction. The included Virtual DJ LE software gives you access to seven effects as shown below.

→ Flanger → Echo → Brake → Backspin
← Over-loop → Flippin double → Beatgrid ←

03) FX on/off button

This button toggles the effect processor on or off.

04) 1/2 beats button (HOTCUE)

The Kontrol D4i allows you to store up to four hot cue points per deck. See pages 14/15: "Setting a hot cue point in pause mode" and "Setting a hot cue point in play mode".

While in autoloop mode, tapping this button allows you to start a 2 bar autoloop.

05) Pitch control fader

Use this fader to adjust the pitch. Slide up to decrease the pitch, slide down to increase the pitch.

06) x½/shift button

Allows you to divide the smartloop length by 2.

While pushing and holding the **shift (47)** button, tapping this button allows you to shift the smartloop with 1 beat.

07) In/smartloop button

This button allows you to set the start point of the loop.

Tapping this button while pushing and holding the **shift (47)** button will toggle the smartloop mode on or off. In smartloop mode, the software makes sure that your loop is always on the beat (actually a quantizing function). Smartloop mode is indicated in the Virtual DJ software by the lock symbol which turns orange when active.



08) Keylock/pitch button

Tapping this button allows you to toggle the Keylock mode on or off. In Keylock mode, the pitch fader allows you to Change the tempo of the song played back while the key of the song stays unchanged. While holding the **shift (47)** button, tapping this button allows you to select the maximum range for the pitch control fader.

— OFF — 8% — 16% — 50% — 100% —

09) Jogwheel

While not in scratch mode, the jogwheel allows you to pitch bend the song.

In scratch mode the jog wheel can be used for scratch effects.

Pushing and holding the **shift (47)** button while turning the jogwheel allows you to seek through the song (see page 15).

10) Cue button

Push the cue button during playback to return to the position at which playback is started or to the first cue point (if set).

11) Sync/master button

Automatically matches the corresponding deck's tempo with the other deck's tempo.

Pushing and holding the **shift (47)** button while tapping this button allows you to set up a deck as a master for sync play.

12) Parameter 1 control

The Parameter 1 and 2 controls allow you to adjust effect parameters. Note that not all effects require two parameter controls.

13) Auto loop button

This mode allows you to create various auto loops by pressing the buttons: **1/2 beats (04)**, **2/4 beats (15)**, **3/8 beats (22)**, **4/16 beats (23)**.

14) Parameter 2 control

The Parameter 1 and 2 controls allow you to adjust effect parameters. Note that not all effects require two parameter controls.

15) 2/4 beats button (HOTCUE)

The Kontrol D4i allows you to store up to four hot cue points per deck. See pages 14/15: "**Setting a hot cue point in pause mode**" and "**Setting a hot cue point in play mode**". While in autoloop mode, tapping this button allows you to start a 4 bar autoloop.

16) Key control

This control allows you change the key of the song while the tempo remains unchanged.

17) Sample rec/smartcue button

This button allows you to start/stop recording a sample.

Tapping this button while pushing and holding the **shift (47)** button allows you to toggle the smart cue mode on or off. In smart cue mode, the software makes sure that your cue point is always on the beat (actually a quantizing function). Smartcue mode is indicated in the Virtual DJ software by the lock symbol which turns orange when active.

**18) Sampler volume control**

Allows you to adjust the sampler volume level.

19) Sample play button

This button allows you to play/pause playback of a previously recorded sample.

20) Sample select up button

Allows you to select a previously recorded sample for playback.

21) Sample select down button

Allows you to select a previously recorded sample for playback.

22) 3/8 beats button (HOTCUE)

The Kontrol D4i allows you to store up to four hot cue points per deck. See pages 14/15: "**Setting a hot cue point in pause mode**" and "**Setting a hot cue point in play mode**".

While in autoloop mode, tapping this button allows you to start a 8 bar autoloop.

23) 4/16 beats button (HOTCUE)

The Kontrol D4i allows you to store up to four hot cue points per deck. See pages 14/15: "**Setting a hot cue point in pause mode**" and "**Setting a hot cue point in play mode**".

While in autoloop mode, tapping this button allows you to start a 16 bar autoloop.

24) Deck 3 button**25) x2 button**

Allows you to multiply the loop length by 2. While pushing and holding the **shift (47)** button, tapping this button allows you to shift the loop by 1 beat.

26) Out/reloop button

This button allows you to set the endpoint of the loop or to exit loop playback.

While pushing and holding the **shift (47)** button, pushing this button allows you to reloop.

27) Scratch button

This button allows you to select or deselect scratch mode for the jogwheel. If the scratch mode is not selected, the jogwheel is in jog mode.

28) Play button

This button allows you to toggle between pause mode and playback mode.

Mixer Functions

29) Channel gain

The gain control allows you to adjust the input-sensitivity for a channel. And thus optimally matching the incoming signals to the mixer's internal operation level.

30/31/32) Channel equalizer section (hi/mid/low)

Use the 3 band equalizer to adjust the tone for each channel by using the hi, mid and low controls.

33) Load/view 1 button

Pushing this button loads the selected track in deck 1 and activates the cue function for channel 1. The channel's **cue (36)** button will light up.

While pushing and holding the **shift (47)** button and tapping this button allows you to select the Browser panel (see page 23, "1. Browser/Sampler/Effects/Record").

34) Filter control

Turn this control to apply a filter effect to the corresponding track.

Pushing and holding the **shift (47)** button while tapping the corresponding channel's **cue (36)** button turns the filter effect off. The filter control has a soft takeover function.

35) Load/view 3 button

Pushing this button loads the selected track in deck 3 and activates the cue function for channel 3. The channel's **cue (36)** button will light up.

While pushing and holding the **shift (47)** button, tapping this button allows you to select the Effects panel (see page 23, "1. Browser/Sampler/Effects/Record").

36) Cue button

Tapping this button will allow the audio from that channel to be cued in the headphones. Ensure that **headphones volume (56)** is not completely turned down.

37) Assign crossfader side left button

Allows you to assign the corresponding channel to the left crossfader side.

38) Assign crossfader side right button

Allows you to assign the corresponding channel to the right crossfader side.

39) Channel fader

The fader controls the volume of the corresponding channel.

40) Crossfader

The crossfader allows you to mix smoothly from one source to another (only when both channel faders are up).

41) Master level control

Use to adjust the volume level of the **master RCA (62)** and the **master XLR (61)** outputs.

42) Booth level control

Use to adjust the volume level of the **booth (63)** outputs.

Notes: This is an analog control and does not send MIDI commands.

The booth control is post master volume.

43) Track select encoder

Depending on the **browser panel** (see page 22) you're in, you can use the encoder to select a certain track or folder. Confirm by pressing the encoder.

44) Load/view 2 button

Pushing this button loads the selected track in deck 2 and activates the cue function for channel 2. The channel's **cue (36)** button will light up.

While pushing and holding the **shift (47)** button and tapping this button allows you to select the Sampler panel (see page 23, "1. Browser/Sampler/Effects/Record").

45) Load/view 4 button

Pushing this button loads the selected track in deck 4 and activates the cue function for channel 4. The channel's **cue (36)** button will light up.

While pushing and holding the **shift (47)** button and tapping this button allows you to select the Record panel (see page 22, "1. Browser/Sampler/Effects/Record").

46) Back button

This button in combination with the **track select (43)** encoder allows you to navigate the browser panels. See page 14: "Selecting folders" and "Selecting tracks"

47) Shift button

Pushing and holding this button gives you access to the secondary functions of the: **sample/rec (17)**, **1/2 beats (04)**, **2/4 beats (15)**, **3/8 beats (22)**, **4/16 beats (23)**, **in/smart loop (07)**, **out/reloop (26)**, **sync/master (11)**, **load/view 1 (33)**, **load/view 2 (44)**, **load/view 3 (35)**, **load/view 4 (45)**, **cue (36)** buttons and the jogwheel (09).

Front Functions

48) Touch sensitivity A control

This control allows you to adjust the touch sensitivity of jogwheel A.

49) Touch sensitivity B control

This control allows you to adjust the touch sensitivity of jogwheel B.

50) Microphone input (6,3 mm)

¼" jack balanced microphone input. This input will function best with balanced TRS jacks.

51) Microphone volume control

Use to adjust the volume of the microphone channel.

52) Channel 3 input switch

This switch will only be recognized in the **virtualdj pro full** version.

Note: This switch is only supported by the Virtual DJ Pro Full software. This switch is not supported by the included Virtual DJ LE software.

If you switch in the power of the Kontrol D4i while the switch is in "on" position, the software will not recognize the switch. If this happens, putting the switch in "off" position first and the back in "on" position will solve this problem.

53) X-Fader slope switch

Allows you to select the response (cut/linear) of the crossfader.

54) Channel 4 input switch

This switch will only be recognized in the **virtualdj pro full** version.

Note: This switch is only supported by the Virtual DJ Pro Full software. This switch is not supported by the included Virtual DJ LE software.

If you switch in the power of the Kontrol D4i while the switch is in "on" position, the software will not recognize the switch. If this happens, putting the switch in "off" position first and the back in "on" position will solve this problem.

55) Headphones cue mix control

Allows the user to hear mixed audio of the monitor (cue) audio and the program (master) audio in the headphones. When the knob is rotated to the left only the cue audio will be heard, when in the right position only the program audio will be heard.

Note: This is an analog control and although it does send MIDI commands, this control is not represented in the Virtual DJ LE software GUI.

56) Headphones Volume

Is used to adjust your headphone volume level.

57) Headphones output (6,3 mm)

You can connect a pair of headphones with a minimum impedance of 32 Ohm to this stereo 1/4" jack. The jack should be wired as Tip=left, Ring=right and sleeve=ground.

Back Functions

58) Power on/off switch

Allows you to turn the device on or off.

59) DC in 7,5V 2A

Use the included adapter only.

60) USB connector B

To connect your Kontrol D4i to a PC / laptop/ Mac.

61) Master XLR out L/R

Use these outputs to connect an amplifier/mixer with balanced inputs.

62) Master RCA out L/R

Use these outputs to connect an amplifier/mixer with unbalanced inputs.

63) Booth RCA out L/R

Use these outputs to connect an amplifier/mixer with unbalanced inputs.

64) Channel 4 RCA input

Use this input to connect a CD player or a turntable.

65) Channel 4 line/phono switch

Depending of the position of the Line/ Phono switch you can connect a CD player or a turntable to the **channel 4 (64)** input.

66) GND screw

To attach your turntable's ground wire.

67) Channel 3 RCA input

Use this input to connect a CD player or a turntable.

68) Channel 3 line/phono switch

Depending of the position of the Line/ Phono switch you can connect a CD player or a turntable to the **channel 3 (67)** input.

69) Channel 4 input level control

Use to adjust the level of the **channel 4 (64)** input.

70) Channel 3 input level control

Use to adjust the level of the **channel 3 (67)** input.

Operations

Selecting Folders

- Make sure you're in the **file system/ folder structure panel** (see page 22). Push the **back (46)** button to return to the **file system/ folder structure panel** if you are in the **file/ search results panel**. Turn the **track select (43)** encoder to browse the folders.
- Push the **track select (43)** encoder to open the desired folder. Now you're in the **file/ search results panel** and are ready to select a track as described before.
- Push the **back (46)** button to return to the **file system/folder structure panel**.

Selecting tracks using the track select encoder

- Make sure you have opened the desired folder as described in **Selecting folders** and that you are in the **file/ search results panel** (see page 23)
- Turn the **track select (43)** encoder to browse the tracks.
- Push the **load 1 (33)** button, the **load 2 (44)** button, the **load 3 (35)** button or the **load 4 (45)** button to load the track in respectively deck 1, deck 2, deck 3 or deck 4.

Starting Playback

- Push the **play (28)** button during the pause mode or cue mode to start playback, the LED in the **play (28)** button lights up.

Stop Playback

There are two ways to stop playback:

- Push the **play (28)** button during playback to pause at that point.
- Push the **cue (10)** button during playback to return to the cue point and enter pause condition.

Pausing

- Push the **play (28)** button to pause playback.
- The **play (28)** button blinks when the pause mode is set.
- Playback resumes when the **play (28)** button is pushed again.

Setting a Cue Point

- Push the **play (28)** button to toggle between play mode and pause mode.
- The **play (28)** indicator flashes as the deck is in pause mode.
- Turn the **jogwheel (09)** to go to the desired cue point.
- Push the **cue (10)** button and your cue point will be stored. The cue point will be indicated in the waveform display as shown in figure 6 on page 15.
- Push the **play (28)** button to continue playback.

Setting a hot cue point in pause mode

- Push the **play (28)** button to stop playback.
- The play indicator flashes when the pause mode is set.
- Turn the **jogwheel (09)** to go to the desired Cue point.
- Push the desired hot cue (**1/2 beats (04)**, **2/4 beats (15)**, **3/8 beats (22)**, **4/16 beats (23)**) button and your hot cue point will be stored.
- The stored hot cue point will be indicated in the Waveform display as shown in figure 6 on page 15.
- Push the **play (28)** button to continue playback.

Setting a hot cue point in play mode

- During play mode, push the desired hot cue (**1/2 beats (04)**, **2/4 beats (15)**, **3/8 beats (22)**, **4/16 beats (23)**) button.
- The hot cue point is stored while playback resumes.
- The hot cue point will be indicated in the **waveform display** as shown in figure 6.

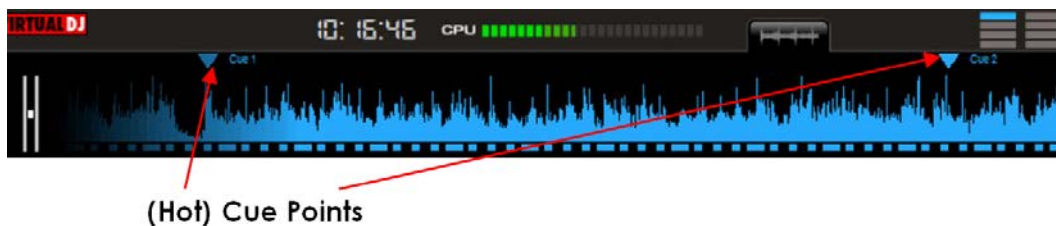

Fig. 06

Deleting a hot cue point

- Push and hold the **shift (47)** button while tapping the corresponding hot cue button (**1/2 beats (04)**, **2/4 beats (15)**, **3/8 beats (22)**, **4/16 beats (23)**) to delete a hotcue point.

Cueing

- "Cueing" is the action of preparing for playback.
- Push the **cue (10)** button, the player will enter cue mode, playback returns to the cue point and the deck will enter pause mode, the **cue (10)** button lights up and the **play (28)** button flashes. When the **play (28)** button is pushed, playback will start from the cue point.
- If the **cue (10)** button is pushed after the search operation or the scanning operation, playback returns to the cue point and the deck will enter pause mode.

NOTE: While in cue mode, and the **cue (10)** button is pushed and hold, playback will start from the cue point, when the button is released, the player will return to the cue mode automatically, it allows you to check the cue point.

Seek (fast forward/fast backward)

Seeking is a function used for moving quickly forward or backward through a track while pushing and holding the **shift (47)** button and turning the **jogwheel (09)**.

- Push and hold the **shift (47)** button while turning the jogwheel. The track will play fast forward or fast backward and the sound is audible.
- Turn the jogwheel clockwise to scan in forward direction, counterclockwise to scan in reverse direction.

Changing pitch of the song

- Set the desired pitch bend range for the **pitch control fader (5)** by pushing and holding the **shift (47)** button and tapping the **keylock/pitch (08)** button. Make sure that the **pitch control fader (05)** is activated (**keylock/pitch (08)** button is lit).
- Adjust the BPM by sliding the **pitch control fader (05)** up or down.
- Slide the **pitch control fader (05)** up to decrease BPM, or down to increase BPM. The adjustment range is +/- 8%, 16%, 50 or 100% depending on the range previously set up.

Pitch bending

- Turn the jogwheel during playback of a track to change the BPM temporarily.
- Turn the **jogwheel (09)** clockwise during play to increase the BPM and counterclockwise to decrease the BPM. The faster you turn the wheel, the more the BPM changes. The adjustment range is +/- 20%.
- When you release the **jogwheel (09)**, the track will return to the BPM set with the **pitch control fader (05)**.

Loop play

- Push the **in/smart loop (07)** button to set the loop start point. The button will start blinking.
- Push the **out/reloop (26)** button to set the loop end point. After the end point is set, the playback will enter the loop play from start point to end point repeatedly. Both the **in/smart loop (07)** button and the **out/reloop (26)** button will blink.
- Tap the **out/reloop (26)** button to cancel the loop play. Both the **in/smart loop (07)** and **out/reloop (26)** buttons will dim.
- Pushing and holding the **shift (47)** button while tapping the **out/reloop (26)** button while in loop play, allows you to change the endpoint by turning the **Jogwheel (09)**. The **out/reloop (26)** button will blink while the **in/smart loop (07)** button will dim. Confirm the new endpoint by pushing and holding the **shift (47)** button while tapping the **loop out/reloop (29)** button. Both the **in/smart loop (07)** button and the **out/reloop (26)** button will blink again, indicating loop play is active.
- Pushing and holding the **shift (47)** button while tapping the **in/smart loop (07)** button while in loop play, allows you to change the startpoint by turning the **Jogwheel (09)**. The **in/smart loop (07)** button will blink while the **out/reloop (26)** button will dim. Confirm the new endpoint by pushing and holding the **shift (47)** button while tapping the **loop in/smart loop (07)** button. Both the **in/smart loop (07)** button and the **out/reloop (26)** button will blink again, indicating loop play is active.
- The **1/2 beats (04)**, **2/4 beats (15)**, **3/8 beats (22)**, **4/16 beats (23)** buttons and the **x2/shift (25)** and **x½/shift (06)** buttons allow you to shorten or expand the length of the recorded loop while loop play is active.
- While pushing and holding the **shift (47)** button, the **x2/shift (25)** and **x½/shift (06)** buttons allow you to shift the recorded loop by 1 beat while loop play is active.

Auto loop play

- Push the **auto loop (13)** button. The **auto loop (13)** will light.
- Set the loop length using the **1/2 beats (04)**, **2/4 beats (15)**, **3/8 beats (22)**, **4/16 beats (23)** buttons and the **x2/shift (25)** and **x½/shift (06)** buttons. Smartloop play will start immediately.
- Pushing the **out/reloop (26)** button will cancel smart loop play.

Reloop

- Push and hold the **shift (47)** button and tap the **out/reloop (26)** button. The song will return to the last selected loop.
- Push the **out/reloop (26)** button, the loop play function is canceled.

Recording a sample

- Select a memory space in which you want to store your new sample, by using the **sample select up (20)** and **sample select down (21)** buttons.
- Push the **sample rec/smart cue (17)** button to start recording.
- When finished recording, push the **sample rec/smart cue (17)** button again.

Sample playback

- Select a memory space in which you want to store your new sample, by using the **sample select up (20)** and **sample select down (21)** buttons.
- Push the **sample play (19)** button to toggle playback/pause of the sample.

Software Installation

System requirements:

PC

Minimum system requirements:

- Intel® Pentium® 4 or AMD Athlon™ XP
- 1280x1024 resolution
- DirectX compatible soundcard
- 512MB RAM
- 50MB free on the hard drive

Recommended system requirements:

- Intel® Core™ 2 or AMD Athlon™ X2
- 1280x1024 resolution
- Multi-channel DirectX compatible soundcard
- 1024MB RAM
- 200MB free on the hard drive

Additional requirements for Video mixing:

- 2048MB (2GB) RAM
- ATI™ or NVIDIA® video card w/256MB of Dedicated DDR3 RAM
- Video card must support dual-screen output

Supported Operating System:

- MINIMUM: Microsoft® Windows XP SP3 or newer
- RECOMMENDED: Microsoft® Windows 7 Professional 32-bit
- Microsoft® Windows 95, 98, ME, or older are not supported

Mac

Minimum system requirements:

- Intel® processor
- Mac OS X v10.5.x
- 1024x768 resolution
- CoreAudio compatible soundcard
- 1024MB RAM
- 50MB free on the hard drive

Recommended system requirements:

- Intel® processor
- Mac OS X v10.6.x
- 1440x900 resolution
- Multi-channel CoreAudio compatible soundcard
- 2048MB (2Gb) RAM
- 200MB free on the hard drive

Additional requirements for Video mixing:

- ATI™ or NVIDIA® video chipset w/256MB of Dedicated DDR3 RAM
- Video must support dual-screen output

Supported Operating System and Processor Platforms:

- Minimum: Mac OS X v10.5 Leopard on Intel processor platform
- Recommended: Mac OS X v10.6.x Snow Leopard on Intel processor platform
- Apple® Mac OS X 10.4.x Tiger or older are not supported
- Motorola® (PowerBook® G4) processor platform or older are not supported

Installation procedure:

- Be sure to turn off the power supply in all equipment as well as the computer.
- Use the USB cable to connect the Kontrol D4i and your computer.
- Turn on the power supply of your Kontrol D4i, your computer and then your amplifier/ active speakers.
- Insert the CD-ROM into the computers CD-drive and follow the instructions.

Running the setup program.

Follow the steps below.

01) If the installation program on your CD doesn't start automatically, start it manually by double clicking install_virtualdj_le_v7.0.5.rar file on the CD.

02) The welcome screen will pop up.

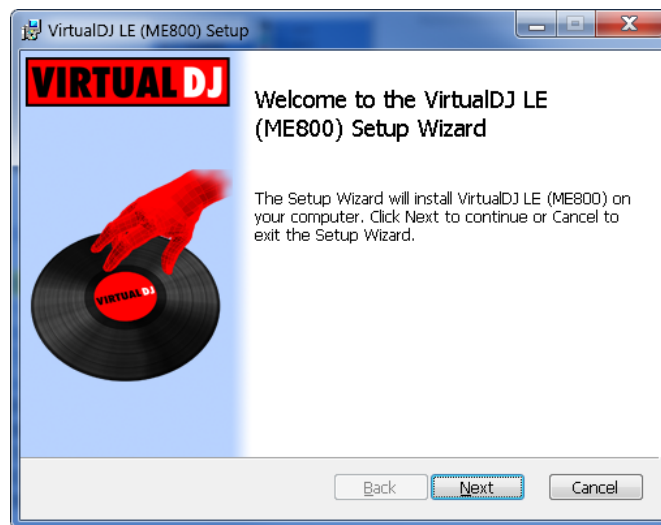

Press **Next** when finished reading the screen.

03) Now the readme file as shown below will pop up.

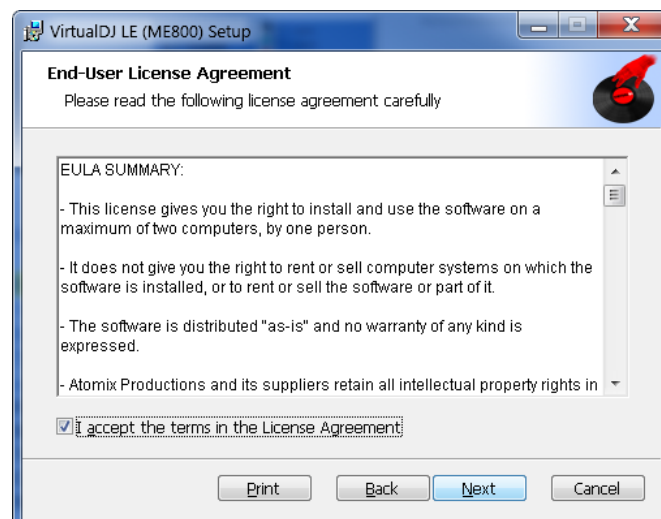

Check the "I accept" checkbox and click **Next**.

04) The Setup screen will pop up.

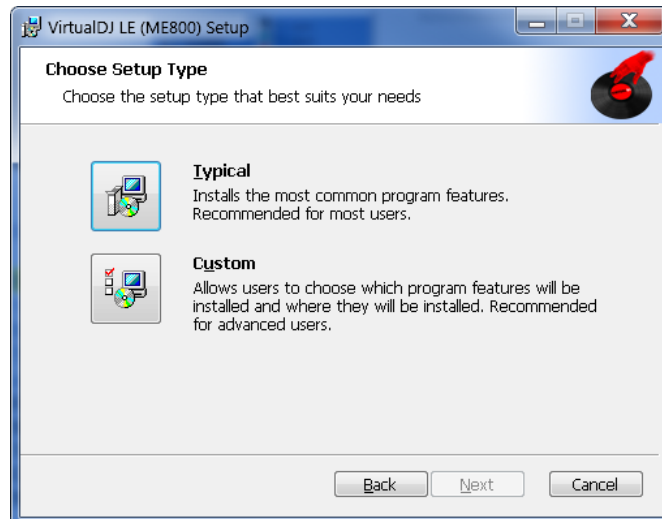

Click **Typical**.

05) The Installation screen will pop up.

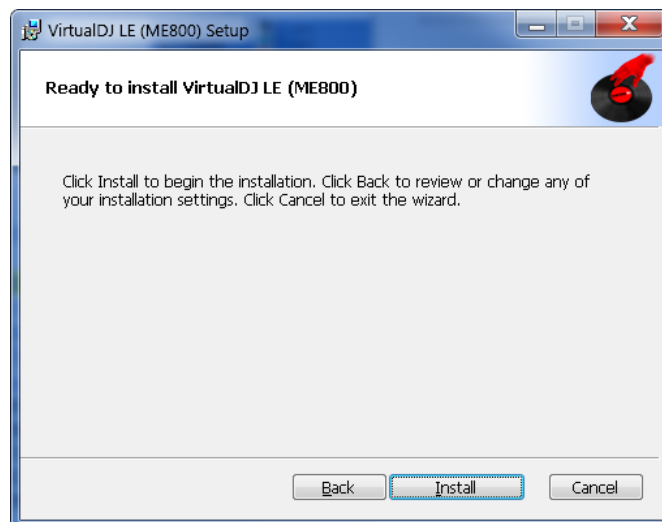

Click **Install**.

06) If the installation is finished the screen below will pop up.

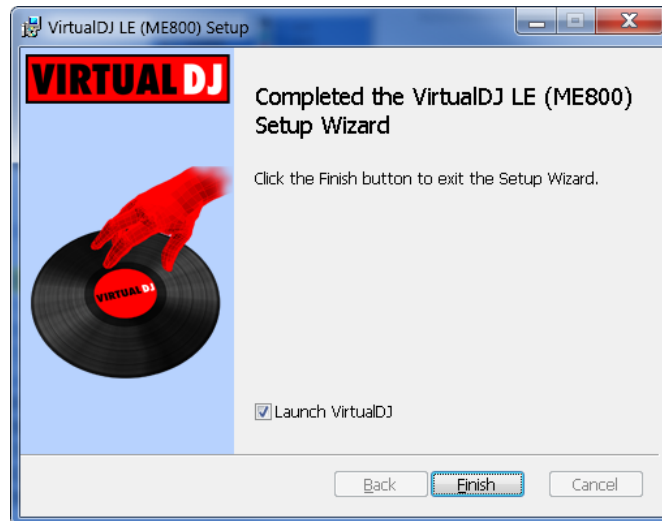

Press the **finish** button to complete the installation.

Running the Virtual DJ-software for the first time

- 01) Double click the Virtual DJ icon on the desktop. A pop up screen asking you to enter your serial number will pop up.
- 02) Double click the Virtual DJ icon on the desktop. A pop up screen asking you to enter your serial number will pop up.
- 03) Enter the serial number you received with your purchase (sticker on inside CD-cover flap) and click the OK button.
- 04) Virtual DJ will check for the currently latest version (this can be disabled in the configuration section). The Virtual DJ user interface will appear.



- 05) Click the Config button (upper right). The following screen will pop up.

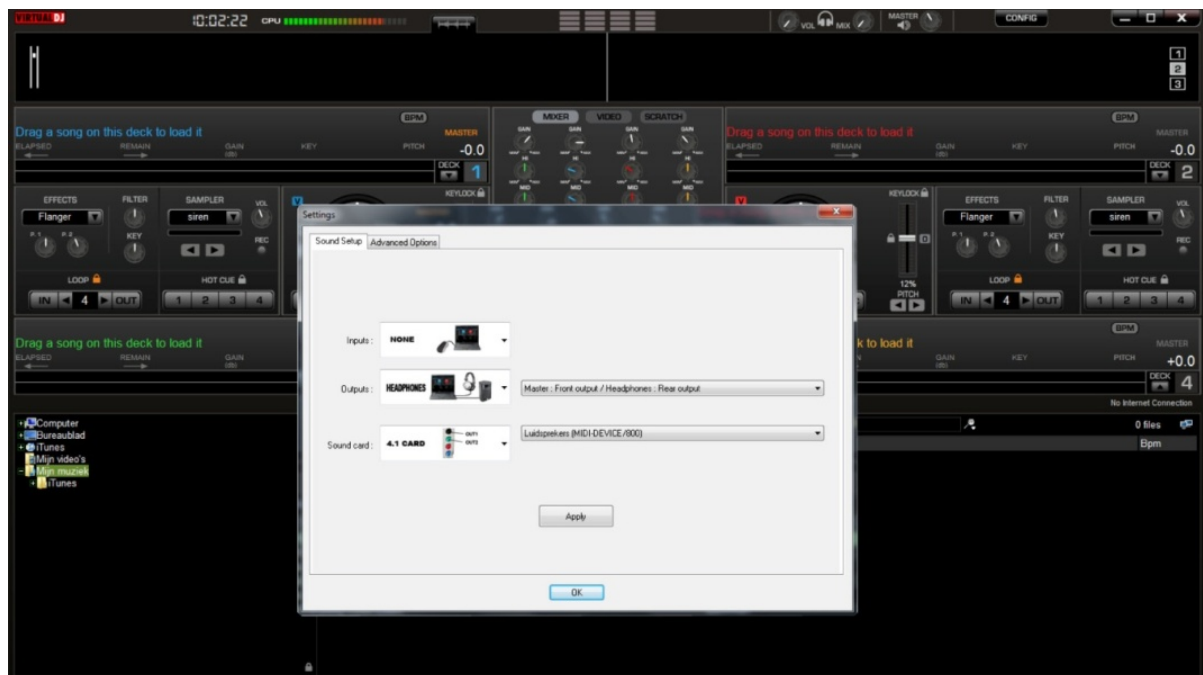

In the Sound Setup tab you can optimize the soundcard settings. We suggest using the settings below which give you access to all outputs on your Kontrol D4i. Other configurations can limit your outputs.

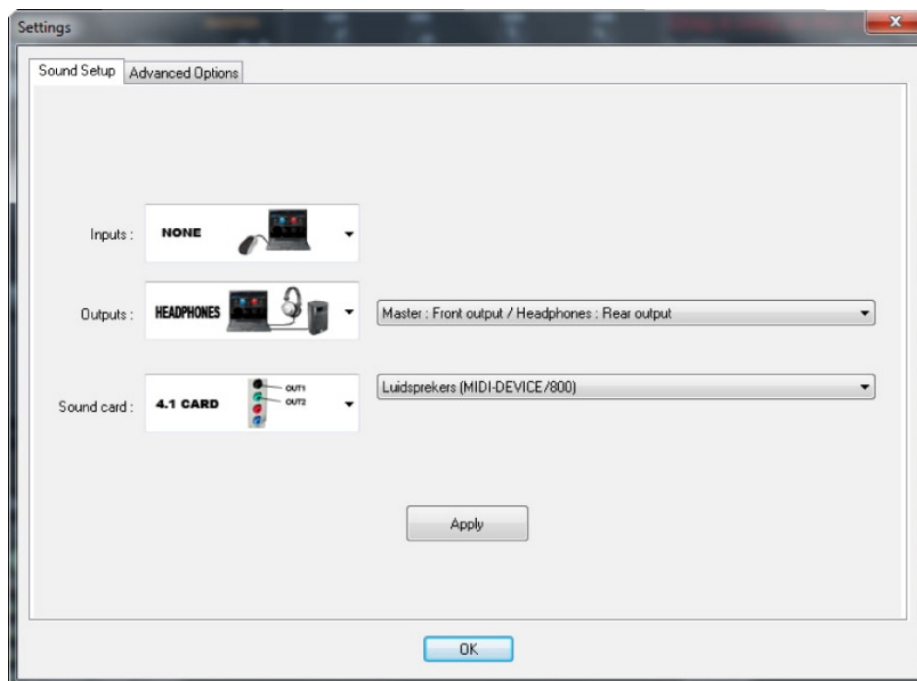

On the right side of the soundcard menu are two drop down menus, which can be used to choose respectively the first and the second soundcard.

In the example shown above, the first two channels of the Kontrol D4i's internal soundcard are routed to the master outputs and second two channels are routed to the headphones output.

If the setup process was carried out correctly, press the apply button and then press the OK button.

Make sure the Kontrol D4i is connected with your computer's USB port and is switched on before setting up your soundcards, otherwise you won't be able to access your Kontrol D4i's built in soundcards.

For more possibilities, we suggest reading the Virtual DJ Quick guide. You can download the Virtual DJ Quick guide from: <http://www.virtualdj.com/wiki/PDFManuals.html>

Interface zones

Before beginning to use Virtual DJ, familiarize yourself with the controls and zones of the software. Upon opening the application, an interface is displayed. Interfaces called skins feature different configurations, layouts and functionality of the software. Let us begin with selecting the Internal Mixer interface to become familiar with the most important features of the software. To select a different skin while the software is running, click on the Config menu and select the skins tab.



01) Browser/Sampler/ Effects/ Record

Browse your music folders, create, edit and save your playlists, adjust effects, video and audio, record and save mixes.

02) Deck 1 Controls

Drag and drop music from the browser to this virtual deck. Track title, beats per minute display, counters and transport control.

03) Deck 2 Controls

Same as Deck 1.

04) Deck 3 Controls

Deck 3 zone (closed in the picture above). Open the virtual deck by clicking on the activation button next to number 3. Now the deck 3 zone will open while the deck 1 zone will close.

05) Deck 4 Controls

Deck 4 zone (closed in the picture above). Open the virtual deck by clicking on the activation button next to number 5. Now the deck 4 zone will open while the deck 2 zone will close.

06) Center Panel

Multiple panels can provide access to crossfader, gain controllers, volume controllers, PFL buttons, video controllers, video preview windows, effect controllers, time code and scratch interface.

07) Rhythm window

This window tracks the waveform of each song loaded or playing on the decks. This area also features Computer Beat Grid (CBG) used for visual mixing and beat matching.

Browser panels

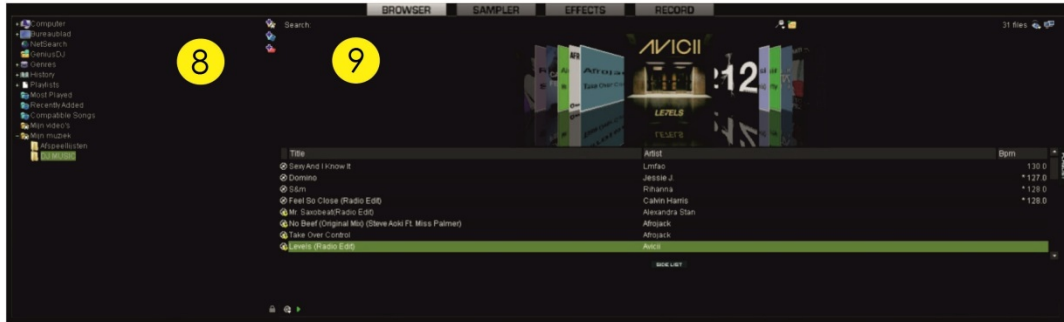

08) File System/Folder Structure

09) File/Search Results

For more information on the Virtual DJ software, we suggest checking the Support Section on <http://www.virtualdj.com/>. Here you can find manuals, forums etc.

Sampler panels

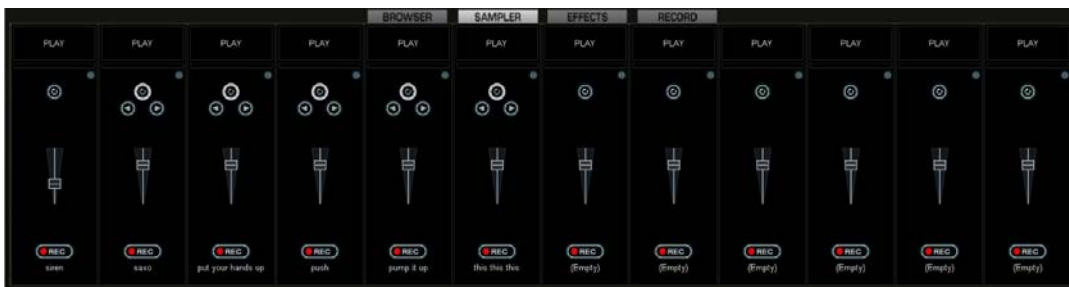

Effects panels



Record panels



Maintenance

The DAP Audio Kontrol D4i requires almost no maintenance. However, you should keep the unit clean. Disconnect the mains power supply, and then wipe the cover with a damp cloth. Do not immerse in liquid. Do not use alcohol or solvents.

Keep connections clean. Disconnect electric power, and then wipe the audio connections with a damp cloth. Make sure connections are thoroughly dry before linking equipment or supplying electric power.

Troubleshooting

Problem	Probable cause(s)	Remedy
Controller is completely dead.	No power.	Check that power is switched on and the power adapter is plugged in.
Controller is not recognized in windows.	No driver installed.	<ol style="list-style-type: none"> 1. Unplug all other USB cables and devices. 2. Plug in your controller's USB cable. 3. Check if your driver (ME 800) is installed and running. <p>Windows Vista & Windows 7: Start/Devices and Printers/.</p> <p>Windows XP: Start/Control Panel/System/Device Manager/.</p>
No sound from controller	Incorrect soundcard settings.	<p>Check the settings in the config menu.</p> <p>See page 21: Running the Virtual DJ-software for the first time of this manual.</p>
No sound from the controllers headphone output.	Incorrect soundcard settings.	<p>Check the settings in the config menu.</p> <p>See page 21: Running the Virtual DJ-software for the first time of this manual.</p>
No access to the controller's built in soundcards during setup.	Controller is not connected to your PC's USB port or is switched off.	<ol style="list-style-type: none"> 1. Check if your controller is switched on. 2. Check if the controller is connected to your PC 3. Check your USB cable.
Virtual DJ pro does not react to the controller.	No correct driver in folder devices.	<p>Window Vista & Windows 7: Make sure that c:\Users\{Username}\My Documents\VirtualDJ\Devices contains ME800.xml</p> <p>Window Windows XP: Make sure that c:\Documents and Settings\{Username}\My Documents\VirtualDJ\Devices contains ME800.xml</p> <p>Mac OS X: Make sure that ./Users/{Username}/Documents/VirtualDJ/Devices contains ME800.xml</p> <p>File can be downloaded from http://www.highlite.nl</p>

	<p>No correct mapping in folder mappers.</p>	<p><u>Window Vista & Windows 7:</u> Make sure that c:\Users\{Username}\My Documents\VirtualDJ\Mappers\ contains Generic ME-800.xml</p> <p><u>Window Windows XP:</u> Make sure that c:\Documents and Settings\{Username}\MyDocuments\VirtualDJ\Mappers\ contains Generic ME-800.xml</p> <p><u>Mac OS X:</u> Make sure that ./Users/{Username}/Documents/VirtualDJ/Mappers/ contains Generic ME-800.xml File can be downloaded from http://www.highlite.nl</p>
	<p>No correct skin in folder skins.</p>	<p><u>Window Vista & Windows 7:</u> Make sure that c:\Users\{Username}\My Documents\VirtualDJ\Skins\ contains ME800.zip</p> <p><u>Window Windows XP:</u> Make sure that c:\Documents and Settings\{Username}\My Documents\VirtualDJ\Skins\ contains ME800.zip</p> <p><u>Mac OS X:</u> Make sure that ./Users/{Username}/Documents/VirtualDJ/Skins/ contains ME800.zip File can be downloaded from http://www.highlite.nl</p>
<p>Sound from controller despite all faders are in minimum position.</p>	<p>Incorrect soundcard settings.</p>	<p>Check the settings in the config menu. See page 21: Running the Virtual DJ-software for the first time of this manual.</p>
<p>Analog input 3 and 4 are not functioning with Virtual DJ LE software.</p>	<p>The analog inputs 3 and 4 are only functional with the Virtual DJ Pro software.</p>	<p>Purchase a Virtual DJ Pro license.</p>
<p>Analog input switches 3 and 4 are not functioning with Virtual DJ Pro software.</p>	<p>The switches where in on position while switching the device off.</p>	<p>Move the switches from on to off. Now the software will recognize the switch.</p>

Product Specification

Channels: 4
 Decks: 4
 Controllers: 102
 16Bit 44,1Khz
 1 x Microphone, 6,3mm Jack

Inputs: 2x Line, RCA
 2x Phono, RCA

Soundcard: 4 In/ 4 Out
 Sampling Frequency: 44,1 KHz
 Audio Resolution : 16 bit
 Output level: 1,2V+-0.2V
 THD+N: < 0,05%
 S/N: > 80dB
 Crosstalk: > 80dB

Outputs: 1 x Master unbalanced, RCA
 1 x Master balanced, XLR
 1 x Booth, RCA
 1 x Headphone, 6,3mm Jack

Power-supply: External adapter 7,5V DC
 Power consumption: 2000mA
 Dimensions: 334 x 475 x 70 mm (LxWxH)
 Weight: 2,65 Kg

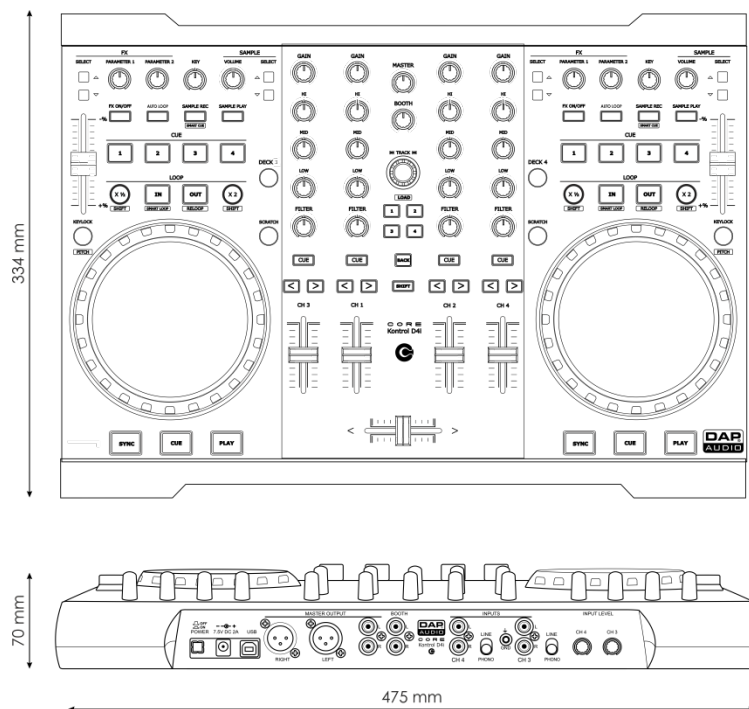

Design and product specifications are subject to change without prior notice.



Website: www.Dap-audio.info
 Email: service@highlite.nl

Appendix 1: Midi Implementation

DAP Audio

Date: 20-06-2012

Model: Kontrol D4i

MIDI Implementation Chart

Function		Transmitted	Recognized	Remarks
Basic channel	Default	1,2, 3, 4, 5, 6	X	
	Changed	X	X	
Mode	Default			
	Messages	X	X	
	Altered			
Note number		20 ₍₁₆₎ - 75 ₍₁₆₎	X	*1
	True voice	X	X	
Velocity	Note ON	O	X	00 ₍₁₆₎ = off, 7F ₍₁₆₎ = on
	Note OFF	X	X	
After touch	Key's	X	X	
	Channel	X	X	
Pitch bend		O	X	*3
Control change		05 ₍₁₆₎ - 3B ₍₁₆₎	X	*2
Prog Change		X	X	
	True#	X	X	
SysEx		X	X	
Common	Song pos	X	X	
	Song Sel	X	X	
	Tune	X	X	
System real time	Clock	X	X	
	Commands	X	X	
Aux Messages	Local			
	ON/OFF	X	X	
	All Notes OFF	X	X	
	Active Sense	X	X	
	Reset	X	X	

O: YES Mode 1: OMNI ON, POLY Mode 2: OMNI ON,
MONO

X: NO Mode 3: OMNI OFF, POLY Mode 4: OMNI OFF, MONO

*1: Note numbers

Deck 1: MIDI Channel 1
 Deck 2: MIDI Channel 2
 Deck 3: MIDI Channel 3
 Deck 4: MIDI Channel 4

Note number	Function
20	FX select up
21	FX select down
22	sample select up
23	sample select down
24	FX on/off
25	autoloop
26	sample rec
27	sample play
28	1
29	2
2A	3
2B	4
2D	in
2E	out
2F	scratch
30	keylock
31	sync
32	cue
33	play
35	X1/2 shift
36	X2 shift
37	deck switch

Mixer: MIDI Channel 5

Note number	Function
60	track encoder (push)
66	ch. 1 cue
67	ch. 2 cue
68	ch. 3 cue
69	ch. 4 cue
6A	ch. 1 crossfader assign L
6B	ch. 1 crossfader assign R
6C	ch. 2 crossfader assign L
6D	ch. 2 crossfader assign R

6E	ch. 3 crossfader assign L
6F	ch. 3 crossfader assign R
70	ch. 4 crossfader assign L
71	ch. 4 crossfader assign R
73	ch. 3 input switch
74	ch. 4 input switch
75	fader curve

*2: Control change numbers

Deck 1:	MIDI Channel 1
Deck 2:	MIDI Channel 2
Deck 3:	MIDI Channel 3
Deck 4:	MIDI Channel 4

Control change number	Function
10	Jogwheel
11	FX parameter 1
12	FX parameter 2
13	key
14	sample volume

Mixer:	MIDI Channel 5
--------	----------------

Control change number	Function
5	track encoder
21	ch. 1 gain
22	ch. 1 hi
23	ch. 1 mid
24	ch. 1 low
25	ch. 1 filter
26	ch. 1 fader
27	ch. 2 gain
28	ch. 2 hi
29	ch. 2 mid
2A	ch. 2 low
2B	ch. 2 filter
2C	ch. 2 fader
2D	ch. 3 gain
2E	ch. 3 hi
2F	ch. 3 mid
30	ch. 3 low
31	ch. 3 filter
32	ch. 3 fader
33	ch. 4 gain

34	ch. 4 hi
35	ch. 4 mid
36	ch. 4 low
37	ch. 4 filter
38	ch. 4 fader
39	master volume
3A	headphone mix
3B	headphone volume

Touch sensitivity
controls:

MIDI Channel 6

Control change number	Function
10	touch sens. A
20	touch sens. B

*3: pitch bend channels

Channel number	Function
1	pitch fader deck 1
2	pitch fader deck 2
3	pitch fader deck 3
4	pitch fader deck 4
5	crossfader



©2014 DAP Audio