



IPS-PMA

ORDERCODE D6507



SHOWELECTRONICS FOR PROFESSIONALS

Congratulations!

You have bought a great, innovative product from DAP Audio.

The DAP Audio IPS-PMA brings excitement to any venue. Whether you want simple plug-&-play action or a sophisticated show, this product provides the effect you need.

You can rely on DAP Audio, for more excellent audio products.

We design and manufacture professional audio equipment for the entertainment industry.

New products are being launched regularly. We work hard to keep you, our customer, satisfied.

You can get some of the best quality, best priced products on the market from DAP Audio.

So next time, turn to DAP Audio for more great audio equipment.

Always get the best -- with DAP Audio!

Thank you!



DAP Audio

DAP Audio IPS-PMA Guide

| | |
|-------------------------------------|---|
| Warning | 2 |
| Safety-instructions..... | 2 |
| Operating Determinations..... | 3 |
| Connecting to the mains..... | 3 |
| Description | 4 |
| Features..... | 4 |
| Overview Front panel..... | 4 |
| Overview Back panel..... | 5 |
| Operation | 6 |
| Connecting the device..... | 6 |
| Connecting cables..... | 7 |
| Maintenance | 8 |
| Troubleshooting | 8 |
| Product Specifications | 9 |

WARNING



**FOR YOUR OWN SAFETY, PLEASE READ THIS USER MANUAL CAREFULLY
BEFORE YOUR INITIAL START-UP!**

SAFETY INSTRUCTIONS

Every person involved with the installation, operation and maintenance of this system have to:

- be qualified
- follow the instructions of this manual

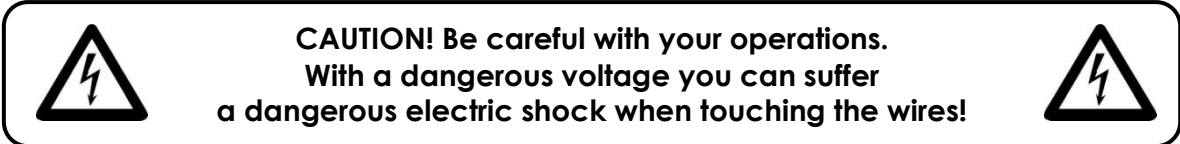

Before you initial start-up, please make sure that there is no damage caused by transportation. Should there be any, consult your dealer and do not use the system.

To maintain perfect condition and to ensure a safe operation, it is absolutely necessary for the user to follow the safety instructions and warning notes written in this manual.

Please consider that damages caused by manual modifications to the system are not subject to warranty.

This system contains no user-serviceable parts. Refer servicing to qualified technicians only.

IMPORTANT:

The manufacturer will not accept liability for any resulting damages caused by the non-observance of this manual or any unauthorized modification to the system.

- Never let the power-cord come into contact with other cables! Handle the power-cord and all connections with the mains with particular caution!
- Never remove warning or informative labels from the unit.
- Never use anything to cover the ground contact.
- Do not insert objects into air vents.
- Do not connect this system to a dimmer pack.
- Do not switch the system on and off in short intervals, as this would reduce the system's life.
- Do not open the device and do not modify the device.
- Do not open this device. Risk: hazardous radiation exposure.
- Only use system indoor, avoid contact with water or other liquids.
- Avoid flames and do not put close to flammable liquids or gases.
- Always disconnect power from the mains, when system is not used. Only handle the power-cord by the plug. Never pull out the plug by tugging the power-cord.
- Make sure you don't use the wrong kind of cables or defective cables.
- Make sure that the signals into the mixer are balanced, otherwise hum could be created.
- Make sure you use DI boxes to balance unbalanced signals; all incoming signals should be clear.
- Make sure that the available voltage is not higher than stated on the rear panel.
- Make sure that the power-cord is never crimped or damaged. Check the system and the power-cord from time to time.
- Make sure that the amplifier is turned down, before turning the power on or off. So you can avoid supersonic frequencies, which could damage your speakers.
- Don't put your equipment next to TV, radio, etc., because of interference or distortion.
- If you connect other parts of the system, be careful of ground loops.
- The best way to avoid ground loops is connecting the electrical system ground to one central point ("star" system). In this case the mixer can act as a central point.
- Before changing the ground, always turn off your amplifier.

- Please read this manual carefully and keep it for future reference. Remember that the amplifier has a better value on the market, if you save the carton and all packing materials.
- Always operate the unit with the AC ground wire connected to the electrical system ground.
- Connecting amplifier outputs to oscilloscopes or other test equipment, while the amplifier is in bridged mode, may damage both the amplifier and test equipment.
- Do not drive the inputs with a signal level bigger, than required to drive the equipment to full output.
- In system setup, the amplifier's output power must be 50%-100% more than the loaded loudspeakers rated power.
- Please turn off the power switch, when changing the power cord or signal cable, or select the input mode switch.
- In typical use, please set the volume at 0dB position.
- Sometimes, when you want to send one signal to more than one amplifier, you should use a signal distributor.
- If your Dap Audio device fails to work properly, discontinue use immediately. Pack the unit securely (preferably in the original packing material), and return it to your Dap Audio dealer for service.
- Allow time to cool down, before cleaning or servicing.
- For replacement use fuses of same type and rating only.
- Prevent distortion! Make sure that all components connected to the DSA have sufficient power ratings. Otherwise distortion will be generated because the components are operated at their limits.
- Avoid ground loops! Always be sure to connect the power amps and the mixing console to the same electrical circuit to ensure the same phase!
- If system is dropped or struck, disconnect mains power supply immediately. Have a qualified engineer inspect for safety before operating.
- If the system has been exposed to drastic temperature fluctuation (e.g. after transportation), do not switch it on immediately. The arising condensation water might damage your system. Leave the system switched off until it has reached room temperature.
- This device falls under protection class I. Therefore it is essential to connect the yellow/green conductor to earth.
- Repairs, servicing and electric connection must be carried out by a qualified technician.
- WARRANTY: Till one year after date of purchase.

OPERATING DETERMINATIONS

If this system is operated in any other way, than the one described in this manual, the product may suffer damages and the warranty becomes void. Any other operation may lead to dangers like short-circuit, burns, electric shock, etc. You endanger your own safety and the safety of others!

Connection with the mains

Connect the device to the mains with the power-plug.

Always pay attention, that the right color cable is connected to the right place.

| International | EU Cable | UK Cable | US Cable | Pin |
|---|--------------|----------|---------------|-------|
| L | BROWN | RED | YELLOW/COPPER | FASE |
| N | BLUE | BLACK | SILVER | NUL |
|  | YELLOW/GREEN | GREEN | GREEN | EARTH |

Make sure that the device is always connected properly to the earth!

Improper installation can cause serious damage to people and property!

Description of the device

Features

- With DC 24V function
- MIC x 5, AUX x 3 and EMC inputs x 2
- Volume control and tone controls
- Built-in chime, muting and priority function
- High S/N ratio

Front panel

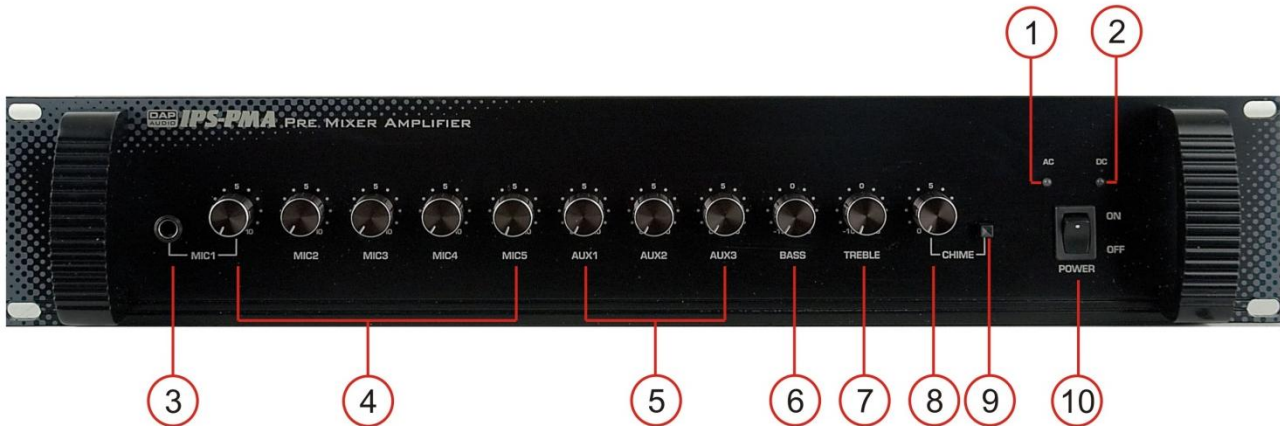

Fig. 1

- 1) AC LED**
Indicates that AC power is connected and the device is turned on. The LED will dim if the mains power fails.
- 2) DC LED**
Indicates that an external 24Vdc power supply is present.
- 3) MIC 1 input**
This input has a priority function. If the IPS-MPA detects a signal at the MIC 1 input, it mutes all other inputs.
- 4) MIC 1 - 5 level**
Use to adjust the input level for MIC 1-5.
- 5) Aux 1 – 3 level**
Use to adjust the input level for AUX 1-3.
- 6) Bass**
Use to adjust the treble frequencies for each channel to your preference.
- 7) Treble**
Use to adjust the treble frequencies for each channel to your preference.
- 8) Chime**
Use to adjust the chime level.
- 9) Chime button.**
Activates the Chime circuit.
- 10) AC Power Switch.**
This is the main Power switch. Press to turn the amplifier on.

Rear panel

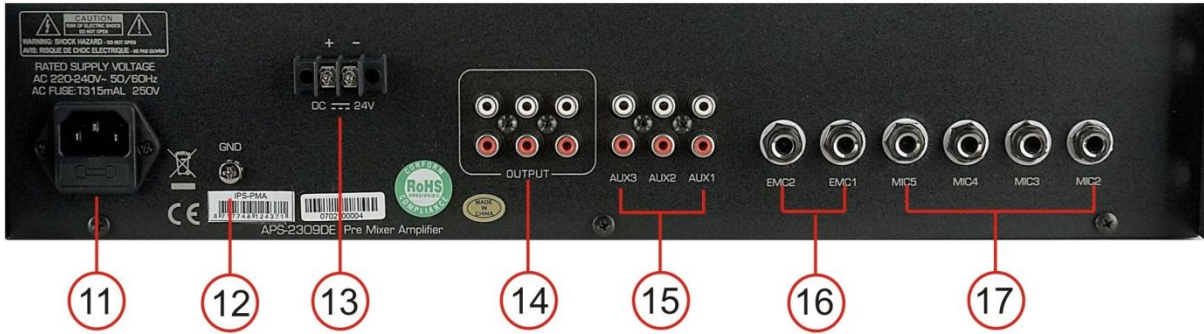

Fig. 2

11) AC Inlet with integrated fuse holder.

This connector is meant for the connection of the supplied main cord. Connect one end of the power cord to the connector, the other end to the mains, then turn on the power switch to operate the unit.

Note: Please make sure that the supply voltage matches the operation voltage before connecting the unit to mains. Replace the fuse only with a fuse of same specification (T315mA).

12) GND Screw.

This screw offers a separate ground connection. Can be useful in case of grounding problems.

13) DC 24V Input.

Used to connect an external back up power supply of 24Vdc (e.g. Battery).

14) Outputs.

Use this RCA connectors to connect up to three power amplifiers to your IPS-MPA.

15) Aux 1-3 input

16) EMC 1-2 input

These inputs have priority (just like MIC 1). If the IPS-MPA detects a signal at one of the EMC inputs, it mutes the normal (non priority) inputs. The EMC inputs starts muting the normal (non priority) channels at an input level of -10dB and completely shuts off the other channels if the level at the EMC input reaches 0dB.

17) MIC 2- 5 input

Operation

Installation

Remove all packing materials from the IPS-PMA. Check that all foam and plastic padding is removed. Secure the equipment into a 19" rack. Connect all cables.

Connecting the device

Below an example of a possible setup.

NOTE: Always turn off and disconnect the amplifier from mains voltage before making any connections.

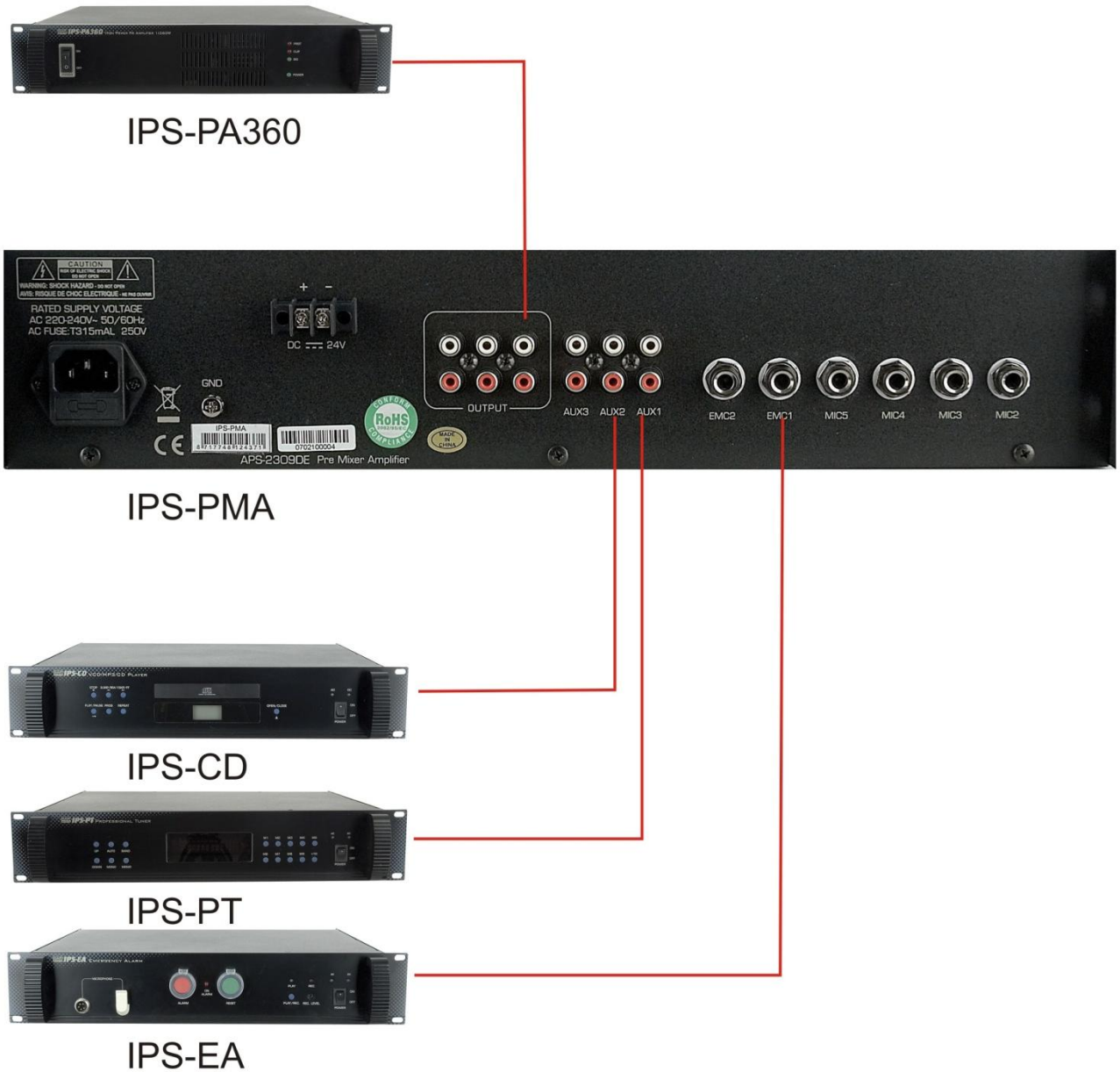

Fig. 3

Connection Cables

Take care of the connector cables, always holding them by the connectors and avoiding knots and twists when coiling them: This gives the advantage of increasing their life and reliability, which is always to your advantage.

Periodically check that your cables are in good condition, that they are correctly wired and that all their contacts are in good condition: a great number of problems (faulty contacts, ground hum, discharges, etc.) are caused entirely by using unsuitable or faulty cables.

Headphones plug

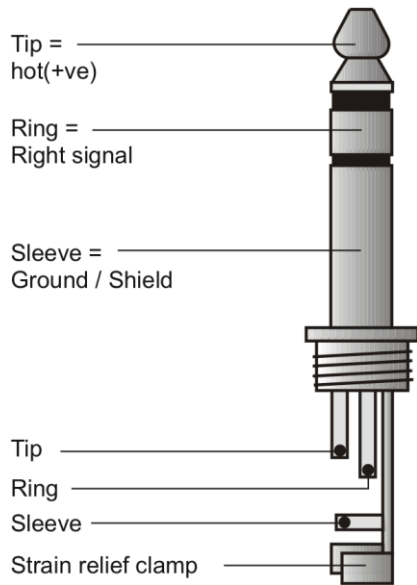

Unbalanced mono 1/4" jack plug

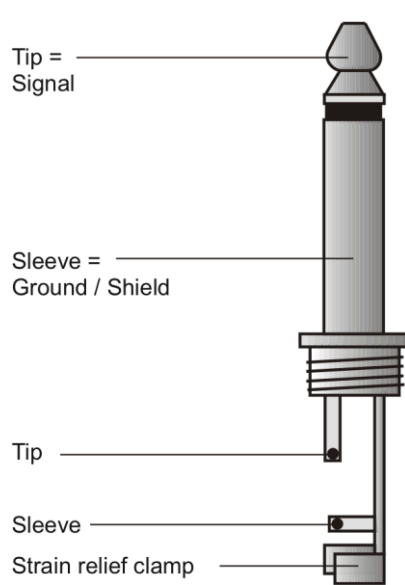

Balanced mono 1/4" jack

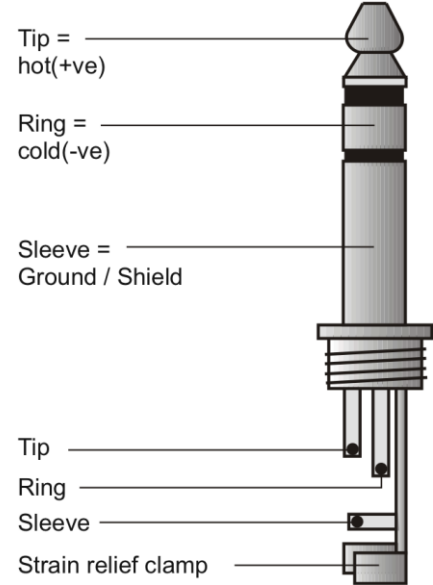

Compensation of interference with balanced connections

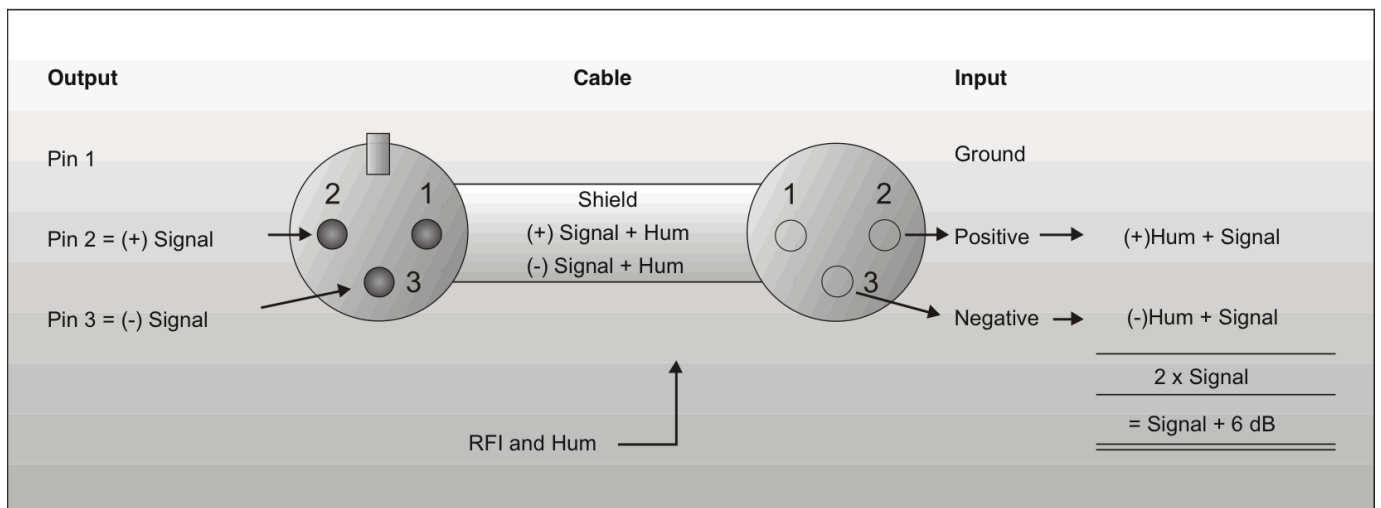

Balanced use with XLR connectors

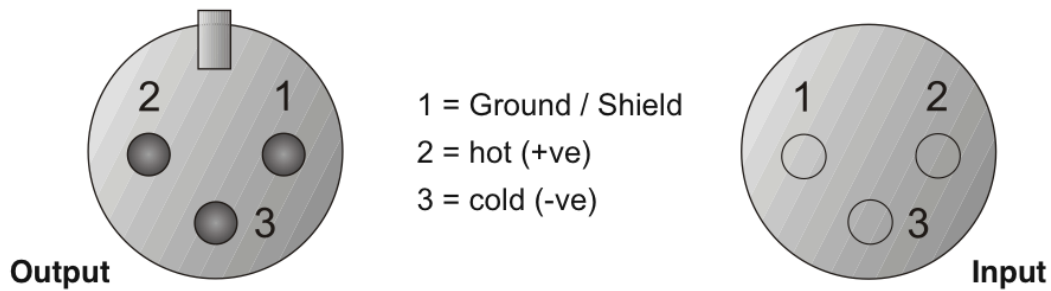

For unbalanced use PIN 1 and PIN 3 have to be bridged

Maintenance

The DAP Audio IPS-PMA requires almost no maintenance. However, you should keep the unit clean. Disconnect the mains power supply, and then wipe the cover with a damp cloth. Do not immerse in liquid. Do not use alcohol or solvents.

Keep connections clean. Disconnect electric power, and then wipe the DMX and audio connections with a damp cloth. Make sure connections are thoroughly dry before linking equipment or supplying electric power.

Replacing a Fuse

Power surges, short-circuit or inappropriate electrical power supply may cause a fuse to burn out. If the fuse burns out, the product will not function whatsoever. If this happens, follow the directions below to do so.

1. Unplug the unit from electric power source.
2. Insert a flat-head screwdriver into a slot in the fuse cover. Gently pry up the fuse cover. The fuse will come out.
3. Remove the broken fuse. If brown or unclear, it is burned out.
4. Insert the replacement fuse into the holder where the old fuse was. Reinsert the fuse cover.
Be sure to use a fuse of the same type and specification. See the product specification label for details.

Troubleshooting

DAP Audio IPS-PMA

This troubleshooting guide is meant to help solve simple problems. If a problem occurs, carry out the steps below in sequence until a solution is found. Once the unit operates properly, do not carry out following steps.

1. If the device does not operate properly, unplug the device.
2. Check the fuse, power from the wall, all cables, etc.
3. If all of the above appears to be O.K., plug the unit in again.
4. If you are unable to determine the cause of the problem, do not open the amplifier, as this may damage the unit and the warranty will become void.
5. Return the amplifier to your Dap Audio dealer.

Product Specifications

| Model | Pre Mixer Amplifier |
|---------------------------|---|
| Power supply | AC 110~120V / 220~240V, 60Hz / 50Hz DC 24V |
| Input sensitivity | MIC1-MIC5: 600Ω, -54dBu, mono unbalanced jack AUX1-3: 47kΩ, -10dBu, Stereo RCA EMC1-2: 47kΩ, -10dBu, mono unbalanced jack |
| Output level | 600Ω / 0dBu |
| Frequency response | 20Hz~20kHz |
| S/N ratio | MIC 80dB, AUX 85dB |
| Tone control | Bass: +/-10dB at 100Hz Treble: +/-10dB at 10kHz |
| Dimensions (W*H*D) | 483*88*370mm |
| Gross weight | 11kg |
| Net weight | 7.8kg |

Design and product specifications are subject to change without prior notice.



Website: www.Dap-audio.info

Email: service@highlite.nl



© 2008 DapAudio.